

Glass Column:

In many operations like reaction, extraction & absorption, the transparency of glass is particular advantage. For such process a range of glass column components are available in Borosilicate glass.

Advantages of Glass Column:

1. Inert to almost all chemicals hence no risk of contamination.
2. Transparency allows visual monitoring of the process, flow patterns, colour changes etc.
3. Almost universal resistance to corrosion.
4. Smooth surface permits easy cleaning and prevents fouling.



DISTILLATION COLUMN

Distillation Column can be constructed either by using pipe sections with Support plates or using column Sections with Packing supports.

Distillation Column are provided with fused shelf where packing support can rest.

Cat. Ref.	DN	L	L1	Minimum packing Size	Usual packing Size
CS3/1000	80	1000	75	9	12
CS4/1000	100	1000	75	12	15
CS6/1000	150	1000	75	15	25
CS6/1500	150	1500	75	15	25
CS9/1000	225	1000	100	20	25

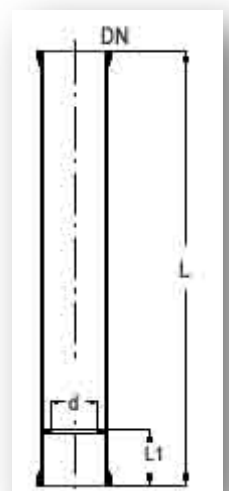

CS9/1500	225	1500	100	20	25
CS12/1000	300	1000	100	25	25
CS12/1500	300	1500	100	25	25
CS16/1000	400	1000	150	25	25
CS16/1500	400	1500	150	25	25
CS18/1000	450	1000	150	25	25
CS18/1500	450	1500	150	25	25
CS24/1000	600	1000	200	40	40

COLUMN SECTIONS WITH THERMOMETER BRANCH

Above Distillation column can be provided with a thermometer branch below the packing shelf at 20° slope.

Cat. Ref.	DN	DN1	L	L1	d
CST3/1000	80	25	1000	125	50
CST4/1000	100	25	1000	125	75
CST6/1000	150	25	1000	125	125
CST6/1500	150	25	1500	125	125
CST9/1000	225	25	1000	150	175
CST9/1500	225	25	1500	150	175
CST12/1000	300	25	1000	150	250
CST12/1500	300	25	1500	150	250
CST16/1000	400	25	1000	200	250
CST16/1500	400	25	1500	200	350
CST18/1000	450	25	1000	200	400
CST18/1500	450	25	1500	200	400
CST24/1000	600	25	1000	250	540



PACKING SUPPORTS

Packing supports Type A are made of fused glass rods. Packing supports Type B (heavy duty) are made of glass plates vertically arranged and tied with PTFE tie rods.

Cat. Ref.	DN	L	Cross Section Area	Max. Load Kgs.	Minimum Packing Size	Type
CP3*	80	10	45%	10	12	A
CP4*	100	12	50%	15	15	A
CP6*	150		55%	30	25	A
CP9*	225	19	60%	50	25	A
CP12*	300	19	65%	75	25	A
HD16	400	70	70%	150	25	B
HD18	450	70	70%	200	25	B
HD24	600	95	70%	300	40	B

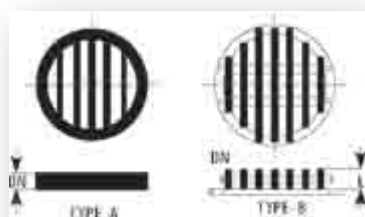

PTFE PERFORATED PLATES

These are used as packing retainers to prevent the packing from lifting due to vapour velocity. These can be clamped between two components without using any gasket.

Cat. Ref.	DN	d	L
TCP3	80	99	7
TCP4	100	132	9
TCP6	150	184	10
TCP9	225	254	12
TCP12	300	340	16

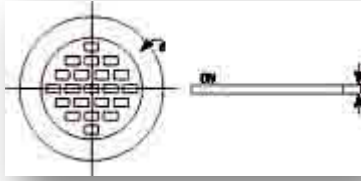

SUPPORT PLATE ASSEMBLY

Support plate assembly can be coupled with a pipe section (PS), so as to use the pipe section as a column section and to fill packings into it. This system provides following advantages over the conventional system of using column section with a packing support.

- 1.Higher cross section area.
- 2.More packing height.
- 3.No separate inventory of column sections.
- 4.Delivery period of pipe section are shorter.

This assembly consist of a glass support plate, a metal flange, a PTFE 'O' ring and nut-bolts.

Cat. Ref.	DN	L	CrossSection Area	Max. Load Kgs.	Suitable Packing Size
LBE3*	80	25	70%	20	12
LBE4*	100	25	70%	30	15
LBE6*	150	50	70%	60	25
LBE9*	225	50	80%	90	25
LBE12*	300	50	80%	150	25

* marked items are available fast.



COLUMN PACKING

COLUMN PACKING - RASCHIG RINGS

Raschig rings upto 25mm are made from Neutral glass. 40mm and 50mm raschig rings are available only in Borosilicate glass.

Cat. Ref.	Size	Bulk Density Kg/Ltr	Specific Surface m ² /m ³	Glass
FC9	9x9	0.6	500	Neutral
FC12	12x12	0.5	400	Neutral
FC15*	15x15	0.4	300	Neutral
FC25*	25x25	0.3	200	Neutral
FCB40	40x40	0.3	160	Borosilicate
FCB50	50x50	0.32	120	Borosilicate



Packings require for various pipe sections (Kgs.)

Pipe Section	Packing size						
	Vol (L)	FC	FC12	FC15	FC25	FCB40	FCB50
PS3/1000	5	3	3	2	-	-	-
PS4/1000	8	-	4	3	3	-	-
PS6/1000	18	-	9	7	7	-	-
PS9/1000	37	-	-	15	15	15	-
PS12/1000	66	-	-	17	30	25	-
PS16/1000	125	-	-	-	65	50	53
PS18/1000	165	-	-	-	90	65	70
PS24/1000	295	-	-	-	-	115	125

Notes of use of Column Packing

1. Due to their low bulk densities, Glass Raschig rings are particularly suitable for packing glass columns.
2. Generally, the ratio of Column diameter to packing diameter should not be less than 8:1
3. When using smaller packing size, a small layer of larger packing should be used on packing support, to prevent the smaller packing falling through.
4. In vacuum application and applications involving high vapour velocities, packing may be lifted and may damage to other parts. To prevent this, a packing retainer (PTFE perforated plates) should be used above the packed section.

Pall Rings

Pall Rings are also available for column packing as per below specification.

Cat. Ref.	Size	Bulk Density Kg/Ltr	Specific Surface m ² /m ³	Glass
FCP30	30x30	0.3	234	Borosilicate
FCP40	40x40	0.3	187	Borosilicate
FCP50	50x50	0.32	140	Borosilicate

* marked items are available fast.



COLUMN ACCESSORIES

COLUMN FEEDPIPE

Feed pipe directs the process fluid to the centre of the column.

Cat. Ref.	DN	DN1	DN2	L	d
FP3	80	25	25	100	12
FP4	100	25	25	125	12
FP6	150	40	25	150	19
FP9	225	40	25	175	19
FP12	300	40	25	225	19
FP16	400	40	25	275	19
FP18	450	40	25	300	19
FP24	600	50	40	450	25

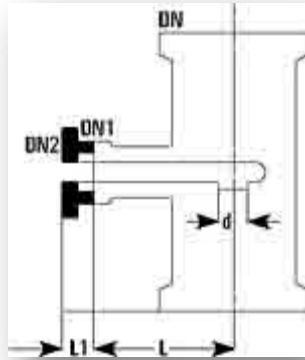

DN refers the nominal diameter of the column.

COLUMN FEED SPARGERS

In column feed spargers holes are provided at three sides of pipe.

Cat. Ref.	DN	DN1	DN2	L	Holes
SPG3	80	25	25	125	21x2mm
SPG4	100	25	25	150	21x2mm
SPG6	150	40	25	200	27x2mm
SPG9	225	40	25	275	27x2mm
SPG12	300	40	25	350	30x3mm
SPG16	400	40	25	450	39x3mm
SPG18	450	40	25	500	39x3mm
SPG24	600	50	40	650	60x3mm

DN refers the nominal diameter of the column.

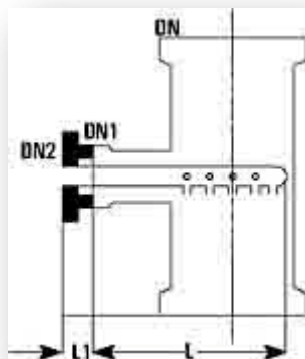

SPRAY FEED SECTION

Spray feed section are provided with circular tube having holes at the bottom.

Cat. Ref.	DN	DN1	L	L1	Holes
FR3	80	25	200	100	21x2mm
FR4	100	25	250	125	21x2mm
FR6	150	40	250	125	27x2mm
FR9	225	40	250	125	27x2mm
FR12	300	40	300	150	30x3mm

For bigger columns, Spray feed pipe with unequal tee should be used.

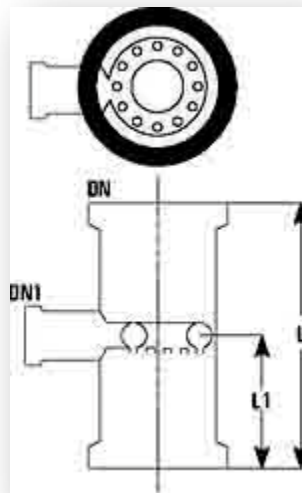

SPRAY FEED PIPES

Spray feed pipes are provided with oval tube having holes at the bottom. These should be used with unequal tees.

Cat. Ref.	DN	DN1	DN2	L	L1	Holes Size	Tee Suitable
FD6	150	80	25	225	125	27x2mm	PTU6/3
FD9	225	100	25	325	150	27x2mm	PTU9/4
FD12	300	150	25	400	200	30x3mm	PTU12/6
FD16	400	150	50	500	200	39x3mm	PTU16/6
FD18	450	150	50	550	200	39x3mm	PTU18/6
FD24	600	150	50	700	200	60x3mm	PTU24/6

DN refers the nominal diameter of the column.

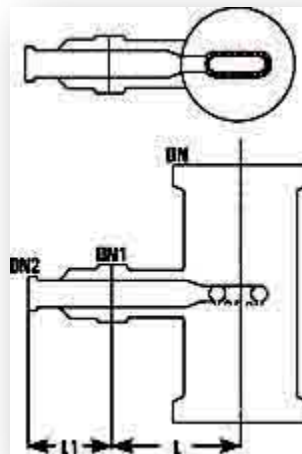

PTFE REDISTRIBUTORS

PTFE redistributors are used to prevent channelling in columns. These can be clamped between two components without using any gasket.

Cat. Ref.	DN	d	L
TL3	80	55	20
TL4	100	80	20
TL6	150	100	20
TL9	225	175	22
TL12	300	215	25
TL16	400	315	25
TL18	450	365	30
TL24	600	420	30

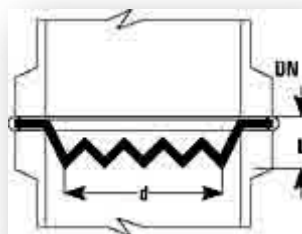

COLUMN ADAPTERS

COLUMN ADAPTORS

Cat. Ref.	DN	DN1	DN2	L	L1	L2
CA3/1/1	80	25	25	150	75	100
CA3/1.5/1	80	40	25	175	100	100
CA3/2/1	80	50	25	175	100	100
CA4/1/1	100	25	25	150	75	125
CA4/1.5/1	100	40	25	175	100	125
CA4/2/1	100	50	25	225	125	125
CA4/3/1	100	80	25	225	125	125
CA6/1/1	150	25	25	200	100	150
CA6/1.5/1	150	40	25	200	100	150
CA6/2/1	150	50	25	250	125	150
CA6/3/1	150	80	25	250	150	150
CA6/4/1	150	100	25	275	150	175
CA9/1.5/1.5	225	40	40	250	150	175
CA9/2/1.5	225	50	40	250	150	175
CA9/3/1.5	225	80	40	300	175	200
CA9/4/1.5	225	100	40	350	175	200
CA9/6/1.5	225	150	40	400	200	250
CA12/1.5/1.5	300	40	40	300	150	225
CA12/2/1.5	300	50	40	300	150	225
CA12/3/1.5	300	80	40	300	150	250
CA12/4/1.5	300	100	40	350	175	250
CA12/6/1.5	300	150	40	425	225	250
CA12/9/1.5	300	225	40	450	225	300
CA16/2/2	400	50	50	400	200	300
CA16/3/2	400	80	50	450	250	300
CA16/4/2	400	100	50	450	250	300
CA16/6/2	400	150	50	550	300	350
CA16/9/2	400	225	50	550	300	350
CA18/2/2	450	50	50	400	200	325
CA18/3/2	450	80	50	450	250	350
CA18/4/2	450	100	50	450	250	350

CA18/6/2	450	150	50	550	300	350
CA18/9/2	450	225	50	550	300	400
CA18/12/2	450	300	50	750	400	400
CA24/2/2	600	50	50	450	200	400
CA24/3/2	600	80	50	500	250	400
CA24/4/2	600	100	50	500	250	400
CA24/6/2	600	150	50	650	300	450
CA24/9/2	600	225	50	650	300	450
CA24/12/2	600	300	50	800	400	500
Column adaptors with DN2 of different size (maximum equivalent to DN1) can be manufactured with the same dimensions.						

Column adaptors with DN2 of different size (maximum equivalent to DN1) can be manufactured with the same dimensions.

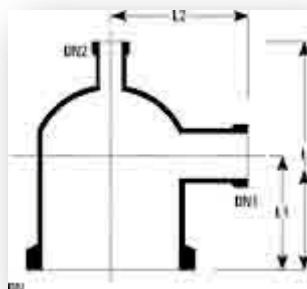

FLAT TOP COLUMN ADAPTORS

These are generally used as headers of Shell and tube heat exchangers and Columns.

Cat.Ref.	DN	DN1	L	L1
CA3/1	80	25	100	75
CA3/1.5	80	40	125	100
CA4/1	100	25	100	75
CA4/1.5	100	40	125	100
CA6/1	150	25	150	100
CA6/1.5	150	40	150	100
CA6/2	150	50	200	125
CA6/3	150	80	200	150
CA9/1.5	225	40	200	150
CA9/2	225	50	200	150

CA9/3	225	80	250	175
CA9/4	225	100	250	175
CA12/2	300	50	250	150
CA12/3	300	80	250	150
CA12/4	300	100	300	175
CA12/6	300	150	350	225

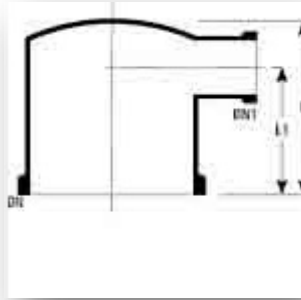

Cat.Ref.	DN	DN1	DN2	L	L1	L2	L3	L4	L5
CAM4/2/1/1	100	50	25	450	300	150	200	125	125
CAM6/3/1/1	150	80	25	450	300	150	200	150	150
CAM9/3/1/1	225	80	25	450	300	150	200	175	200
CAM12/3/1/1	300	80	25	450	300	150	200	225	250

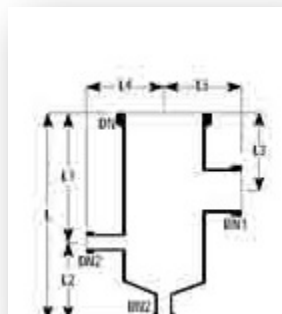

REFLUX DIVIDER

REFLUX DIVIDER - Manually Operated

Reflux dividers are used to take off the distillate from the column. Usually a valve is to be fitted on distillate outlet which controls the reflux coarsely.

Cat. Ref.	DN	DN1	DN2	L	L1	Free Cross Section Cm ²	Max. Product L/hr
RDA3*	80	25	25	200	100	20	300
RDA4*	100	25	25	250	150	50	500
RDA6*	150	25	25	250	150	100	700
RDA9*	225	25	25	375	150	150	900
RDA12*	300	25	25	375	150	250	1100
RDA16	400	40	40	500	200	350	1300
RDA18	450	40	40	600	275	500	1500

DN2 is used for insertion of a thermometer pocket. A bellow is recommended on the distillate outlet DN1.

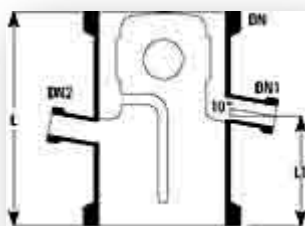

REFLUX DIVIDER -Magnetically Operated

These reflux divider are to be used with a electro-magnet and a timer. These have a swinging funnel mechanism which is operated magnetically from outside to remove the condensate or to return the reflux. Through this, correct control of reflux-ratio is possible. Funnel remains at 100% reflux position when magnet is inactive.

Cat. Ref.	DN	DN1	DN2	L	L1	Free Cross Section Cm ²	Max. Product L/hr
RHM3	80	25	25	375	75	20	90
RHM4	100	25	25	400	75	50	180
RHM6	150	25	25	450	100	100	300
RHM9	225	25	25	550	100	150	500
RHM12	300	25	25	700	100	250	650
RHM16	400	40	40	800	150	350	1000
RHM18	450	40	40	900	150	500	1300

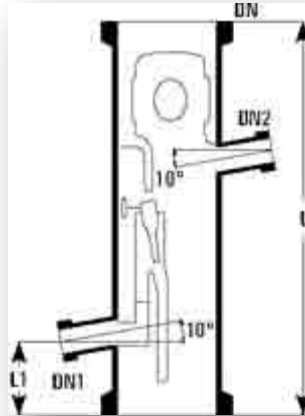

THERMOMETER POCKETS FOR REFLUX DIVIDER

These thermometer pockets are to be used with reflux dividers or column sections. DN refers to the nominal diameter of the Reflux divider or Column.

Cat. Ref.	DN	DN1	d	L
TP3*	80	25	12	75
TP4*	100	25	12	100
TP6*	150	25	12	125
TP9*	225	25	12	175
TP12*	300	25	12	225
TP16	400	40	19	325
TP18	450	40	19	375

* marked items are available fast.

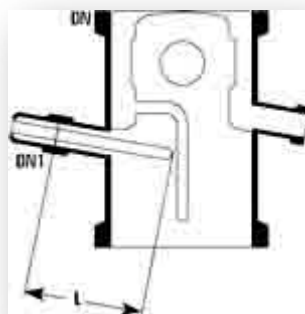

LIQUID SEALS

Liquid seals are to be fitted on the distillate outlet of magnetically operated reflux divider. This prevent the passing of vapour passing directly to the receiver.

Cat. Ref.	DN	DN1	L	Type
LS1*	25	25	200	A
LS1.5	40	25	300	A
LSV1	25	-	200	B

* Marked items are available fast.

